

Cleveland, Model OES-10.10 Electric Combination Oven Performance Test

Application of ASTM Standard
Test Method F 1639-05

FSTC Report # 5011.07.12

**Food Service Technology Center
September 2007**

Prepared by:
Greg Sorensen
Fisher-Nickel, Inc.

Contributors:
David Zabrowski
Frank Zappettini
Fisher-Nickel, Inc.

Prepared for:
Pacific Gas & Electric Company
Customer Energy Efficiency Programs
PO Box 770000
San Francisco, California 94177

© 2007 by Fisher-Nickel, inc. All rights reserved.

The information in this report is based on data generated at the Food Service Technology Center.

Acknowledgments

California consumers are not obligated to purchase any full service or other service not funded by this program. This program is funded by California utility ratepayers under the auspices of the California Public Utilities Commission.

Los consumidores en California no estan obligados a comprar servicios completos o adicionales que no esten cubiertos bajo este programa. Este programa esta financiado por los usuarios de servicios públicos en California bajo la jurisdiccion de la Comision de Servicios Públicos de California.

A National Advisory Group provides guidance to the Food Service Technology Center Project. Members include:

Applebee's International, Inc.
California Energy Commission (CEC)
Denny's Corporation
East Bay Municipal Utilities District
Enbridge Gas Distribution Inc.
EPA Energy Star®
Gas Technology Institute (GTI)
In-N-Out Burger
National Restaurant Association
Safeway, Inc.
Southern California Edison
Underwriters Laboratories, Inc. (UL)
University of California-Berkeley
University of California-Riverside
US Department of Energy, FEMP

Specific appreciation is extended to Cleveland, for supplying the Food Service Technology Center with the OES-10.10 electric combination oven for controlled testing in the appliance laboratory.

Policy on the Use of Food Service Technology Center Test Results and Other Related Information

- Fisher-Nickel, inc. and the Food Service Technology Center (FSTC) do not endorse particular products or services from any specific manufacturer or service provider.
- The FSTC is *strongly* committed to testing food service equipment using the best available scientific techniques and instrumentation.
- The FSTC is neutral as to fuel and energy source. It does not, in any way, encourage or promote the use of any fuel or energy source nor does it endorse any of the equipment tested at the FSTC.
- FSTC test results are made available to the general public through technical research reports and publications and are protected under U.S. and international copyright laws.
- In the event that FSTC data are to be reported, quoted, or referred to in any way in publications, papers, brochures, advertising, or any other publicly available documents, the rules of copyright must be strictly followed, including written permission from Fisher-Nickel, inc. *in advance* and proper attribution to Fisher-Nickel, inc. and the Food Service Technology Center. In any such publication, sufficient text must be excerpted or quoted so as to give full and fair representation of findings as reported in the original documentation from FSTC.

Legal Notice

This report was prepared as a result of work sponsored by the California Public Utilities Commission (Commission). It does not necessarily represent the views of the Commission, its employees, or the State of California. The Commission, the State of California, its employees, contractors, and subcontractors make no warranty, express or implied, and assume no legal liability for the information in this report; nor does any party represent that the use of this information will not infringe upon privately owned rights. This report has not been approved or disapproved by the Commission nor has the Commission passed upon the accuracy or adequacy of the information in this report.

Disclaimer

Neither Fisher-Nickel, inc. nor the Food Service Technology Center nor any of its employees makes any warranty, expressed or implied, or assumes any legal liability of responsibility for the accuracy, completeness, or usefulness of any data, information, method, product or process disclosed in this document, or represents that its use will not infringe any privately-owned rights, including but not limited to, patents, trademarks, or copyrights.

Reference to specific products or manufacturers is not an endorsement of that product or manufacturer by Fisher-Nickel, inc., the Food Service Technology Center or Pacific Gas & Electric Company (PG&E).

Retention of this consulting firm by PG&E to develop this report does not constitute endorsement by PG&E for any work performed other than that specified in the scope of this project.

Contents

	Page
Executive Summary	iii
1 Introduction	1-1
Background	1-1
Objectives.....	1-2
Appliance Description.....	1-3
2 Methods	2-1
Setup and Instrumentation	2-1
Energy Input Rate and Thermostat Calibration	2-1
Preheat and Idle Tests	2-2
Cooking Tests	2-2
Energy Cost Model.....	2-3
3 Results	3-1
Energy Input Rate and Thermostat Calibration	3-1
Preheat and Idle Rate Tests.....	3-1
Cooking Tests	3-3
Ice Load Uniformity Test.....	3-6
Energy Cost Model.....	3-8
4 Conclusions	4-1
5 References	5-1

Appendix A: Glossary

Appendix B: Appliance Specifications

Appendix C: Results Reporting Sheets

Appendix D: Cooking-Energy Efficiency Data

Appendix E: Energy Cost Model

List of Figures and Tables

		Page
Figures	1-1 The Cleveland OES-10.10 combi	1-4
	3-1 Preheat characteristics	3-2
	3-2 Combi part-load cooking-energy efficiency.....	3-5
	3-3 Combi cooking energy consumption profile.....	3-6
	3-4 Ice load pan positions.....	3-7
	3-4 Ice load temperature profile.....	3-7
Tables		Page
	1-1 Appliance Specifications.....	1-4
	3-1 Input and Preheat Test Results	3-1
	3-2 Idle Test Results.....	3-2
	3-3 Whole Chicken Cooking Test Results	3-4
3-4 Ice Load Uniformity Test Results.....	3-8	

Executive Summary

Cleveland's OES-10.10 oven incorporates the latest developments in combination oven technology. In addition to baking and roasting, this combination oven is also capable of steaming, proofing and rethermalizing various food products. Foods can be cooked in a convection oven dry heat only mode, a steam only mode and a combination of dry heat and steam modes. The Cleveland Model OES-10.10 electric combination oven is a boiler-less, closed system design with a 21.6 kW maximum input rate and a programmable control with memory storage of 250 recipes.

The Food Service Technology Center (FSTC) tested the OES-10.10 oven under the controlled conditions of the American Society for Testing and Materials (ASTM) *Standard Test Method for the Performance of Combination Ovens*.¹ Oven performance is characterized by preheat duration and energy consumption, idle energy rate, cooking energy rate and efficiency, production capacity, and water consumption. Cooking tests were conducted with 2 ½-pound whole chickens (deli WOGs).

Cooking-energy efficiency is a measure of how much of the energy that an appliance consumes is actually delivered to the food product during the cooking process. Cooking-energy efficiency is therefore defined by the following relationship:

$$\text{Cooking Energy Efficiency \%} = \frac{E_{\text{Chicken}} + E_{\text{pans}}}{E_{\text{oven}}} \times 100\%$$

A summary of the ASTM test results is presented in Table ES-1.

¹ American Society for Testing and Materials, 2005. Standard Test Method for the Performance of Combination Ovens. ASTM Designation F1639-05, in the Annual Book of ASTM Standards, West Conshohocken, PA.

Executive Summary

Table ES-1. Summary of the Cleveland OES-10.10 Electric Combi Performance.

Rated Energy Input Rate (kW)	21.6
Measured Energy Input Rate (kW)	21.4
Preheat Time (min)	3.6
Preheat Energy (kWh)	1.28
Idle Energy Rate, Combination Mode (kW)	1.7
Whole Chickens	
Light-Load Cooking-Energy Efficiency (%)	65.5 ± 4.2
Heavy-Load Cooking-Energy Efficiency (%)	80.2 ± 2.7
Production Capacity (lb/h)	114.4 ± 8.1

The OES 10.10 demonstrated an impressive 80.2% cooking energy efficiency, while producing 114.4 lbs/h. When cooking the heavy-loads, water usage was 17.0 gallons per hour. During the idle test in combination mode, the consumption rate dropped to only 0.2 gal/h.

The combi's closed system design resulted in a low 1.7 kW idle energy rate. During the ice load tests, the OES-10.10 exhibited strong pan to pan uniformity, with a maximum delay of 1.9 minutes between the fastest and slowest pans.

The test results were used in a model calculation to estimate the annual energy cost to operate the oven. Assuming the OES-10.10 oven cooked 200 lbs of food a day (12 hours), 365 days a year, with two preheats per day, its estimated annual cost to operate would be \$1,602 per year.

1 Introduction

Background

Many food service operations rely heavily on the versatility of ovens. Operators can cook a variety of foods in large quantities with a single appliance. Ovens are often used for cooking fundamental menu items such as fresh-baked desserts, crusty breads, and familiar comfort foods, such as roasted meats and potatoes. In addition to the traditional uses of ovens for roasting and baking, they may be used to cook a surprising range of foods usually associated with other appliances. For example, ovens in high-volume kitchens prepare large quantities of griddle standards such as bacon, eggs, sausages and French toast.

Combination ovens offer even more options with their ability to add steam to the oven cavity. In addition to baking and roasting, a combination oven is also capable of steaming, proofing and rethermalizing various food products. Foods can be cooked in a convection oven dry heat only mode, a steam only mode and a combination of dry heat and steam modes. The programmability of combination ovens also allows food to be cooked partially in one mode at a certain temperature, and then finished in another mode and at a separate temperature. For example, a turkey can be cooked in combination mode at low temperature for several hours, and then stepped to a higher temperature in dry heat mode to finish.

The Food Service Technology Center (FSTC) has focused on the development of standard test methods for commercial food service equipment since 1987. The primary component of the FSTC is a 10,000 square-foot appliance laboratory equipped with energy monitoring and data acquisition hardware, 60 linear feet of canopy exhaust hoods integrated with utility distribution systems, appliance setup and storage areas, and a state-of-the-art demonstration and training facility.

Introduction

The test methods, approved and ratified by the American Society for Testing and Materials (ASTM), allow benchmarking of equipment such that users can make meaningful comparisons among available equipment choices. The test method for combination ovens was submitted to the American Society for Testing and Materials (ASTM) F26 Committee on Food Service Equipment, and accepted as a standard test method (Designation F 1639) in 1995.¹ Further combination oven testing is documented in several FSTC reports.²⁻⁸

The glossary in Appendix A is provided so that the reader has a quick reference to the terms used in this report.

Objectives

The objective of this report is to examine the operation and performance of the Cleveland, Model OES-10.10, electric combination oven under the controlled conditions of the ASTM Standard Test Method. The scope of this testing is as follows:

1. Verify that the appliance is operating at the manufacturer's rated energy input.
2. Determine the time and energy required to preheat the appliance from room temperature to 350°F.
3. Determine the idle energy rate with the oven operating in combination, convection and steam modes.
4. Document the water consumption, cooking energy consumption and cooking-energy efficiency under heavy and light-load conditions using whole chickens as the test product.
5. Determine the product cook time and production capacity.
6. Characterize the combi's cooking uniformity by steaming ice loads.
7. Estimate the annual operating cost for the combination oven using a standard cost model.

Introduction

Appliance Description

The Cleveland, Model OES-10.10 Combi Oven incorporates the latest developments in combi technology. The Advanced Closed System design keeps heat and moisture inside the oven, adjusting humidity levels to suit the product being cooked. The oven is powered by elements located on the left-hand side of the cooking cavity. Steam is introduced by spraying a mist of water onto the heating elements, and air is distributed throughout the cavity using an auto reversing fan.

The 10.10 oven can operate in seven different modes which include dry heat (convection), steam, combination dry heat and steam (combi), retherm, cook and hold, delta t and crisp and tasty. A programmable electronic control panel allows the oven to cook in steps (up to 20) that can combine different cook modes in one program. Up to 250 recipes can be stored for later use, with 8 one-press recipe start buttons. The OES-10.10 also incorporates a “disappearing door” which can be beneficial in tight kitchen spaces.

Appliance specifications are listed in Table 1-1, and the manufacturer’s literature is in Appendix B. The appliance is pictured in Figure 1-1.

Introduction



*Figure 1-1.
The Cleveland OES-10.10
combi.*

Table 1-1. Appliance Specifications.

Manufacturer	Cleveland
Model	OES-10.10
Generic Appliance Type	Electric, half-size, boilerless, combination oven
Rated Input	21.6 kW @ 240V
Technology	Combination dry heat and steam
Construction	All stainless-steel construction
Controls	Programmable control panel with 250 stored recipes
Compartment Capacity	11 half-size (18" x 13") sheet pans, 10 full-size (12" x 20" x 2 ¹ / ₂ ") steam pans, or 3 nine-bird chicken racks
Cavity Size	25" x 33" x 21" (w×d×h)
Dimensions	41" x 34 1/2" x 45 3/4" (w×d×h)

2 Methods

Setup and Instrumentation

The OES-10.10 combi oven was installed in accordance with the manufacturer's instructions and Section 9 of the ASTM standard test method.¹ The oven was positioned on a tiled floor under a 4-foot-deep canopy hood, with the lower edge of the hood 6 feet, 6 inches above the floor and the oven 6 inches inside the vertical front edge of the hood. The exhaust ventilation operated at a nominal rate of 300 cfm per linear foot of hood.

An in-line regulator ensured voltage stayed at a constant 240 Volts. Power and energy were measured with a watt/watt-hour transducer that generated a pulse for each 10 Wh used. Water consumption was measured with an in-line flow sensor installed on the water inlet hose. Oven cavity temperature was monitored with a 24 gauge, type K, Teflon insulated thermocouple wire located in the geometric center of the oven cavity. The condensate water temperature was measured with an additional type K thermocouple wire immersed in the condensate water, just as it entered the floor drain. The transducer and thermocouples were connected to a computerized data acquisition unit that recorded data every 5 seconds.

Energy Input Rate and Thermostat Calibration

The energy input rate was determined by turning the oven on, in combi mode, and measuring the energy consumed from the time the oven first began operating until the time when the elements first cycled off. The energy consumed and the time elapsed were used to calculate the maximum energy input rate. Thermostat calibration was verified by allowing the oven to operate with the thermostat set to the specified operating temperature of 350°F for a period of one hour and then monitoring the oven cavity temperature for an additional sixty minutes.

Methods

Preheat and Idle Tests

The preheat test recorded the time and energy required for the oven, in combi mode, to increase the cavity temperature from $75 \pm 5^\circ\text{F}$ to a temperature of 348°F . Recording began when the oven was first turned on, so any time delay before the energizing of the elements was included in the test. Although the specified operating temperature is 350°F , research at the Food Service Technology Center has indicated that a combination oven is sufficiently preheated and ready to cook when the oven temperature is within 2°F of the oven set point.

After the oven was preheated, it was allowed to stabilize for one hour, and then idle energy and water consumption, in combi mode, were monitored for a 3-hour period.

Since the OES-10.10 has the capability to operate in steam and hot air modes in addition to combi mode, two additional idle tests were performed. The first was an idle test at 350°F with the oven set to hot air mode, and the second was an idle test at 212°F with the oven set to steam mode.

Cooking Tests

Whole Chicken Tests

The oven was tested with (nominal) 2 ½-pound whole chickens loaded onto manufacturer supplied 9-bird chicken racks. Using three racks resulted in a total of 27 chickens for each heavy load test. Light-load tests consisted of one rack for a total of 9 chickens. The temperatures of two chickens per rack were monitored using type-K thermocouples. The chickens were stabilized in a refrigerator at $38 \pm 2^\circ\text{F}$, while the oven operated at 350°F in combi mode. After loading into the oven, the chickens were cooked using a manufacturer supplied 2-step recipe as follows:

Step 1: 320°F in hot air mode for 5 minutes

Step 2: 350°F in Combi mode for the remainder of the cook cycle.

During the testing, energy, time, water consumption, oven temperature, chicken temperature, and condensate drain temperature were measured and

Methods

logged on a computer at 5-second intervals. Product weight was recorded prior to and immediately after each test to determine weight loss.

The cooking tests were replicated three times to ensure that the reported results had an uncertainty of less than $\pm 10\%$. The results from each test run were averaged, and the absolute uncertainty was calculated based on the standard deviation of the results.

The ASTM results reporting sheets appear in Appendix C, and the cooking-energy efficiency data sheets appear in Appendix D of this report.

Energy Cost Model

Combi operating cost was calculated based on a combination of test data and assumptions about typical usage. This provides a standard method for estimating combi energy consumption based on ASTM performance test results. The examples contained in the operating cost model are for informational purposes only, and should not be considered an absolute.

The model assumed a typical 12-hour day, with the operation being broken down into three operating scenarios: preheat, idle and cooking. Two preheats are assumed per day with the remainder being split between idle and cooking periods. During the day, 200 lbs of food would be cooked; 80% under heavy (full) load conditions and 20% under light (single rack) load conditions. The idle time was calculated as the total time of operation minus preheat and cooking times. The total daily energy was the sum total of the preheat, idle and cooking energy consumption. Details of this calculation can be found in Appendix E.

3 Results

Energy Input Rate and Thermostat Calibration

The maximum energy input rate was 21.4 kW, 0.9% lower than the nameplate rate of 21.6 kW, but well within the 5% tolerance of the ASTM standard.

At a thermostat setting of 350°F, the oven cavity temperature averaged 354.4°F over the sixty minute test period. This meant no calibration of the thermostat was necessary.

Preheat and Idle Rate Tests

Preheat Energy and Time

The preheat test consumed 1.28 kWh over a period of 3.6 min. Table 3-1 summarizes the results of the input rate and preheat tests. Figure 3-1 shows the oven's energy consumption rate and the cooking cavity temperature during the preheat test.

Table 3-1. Input and Preheat Test Results.

Rated Energy Input Rate (kW)	21.6
Measured Energy Input Rate (kW)	21.4
Preheat to Operational Capacity:	
Time (min)	3.6
Energy (kWh)	1.28

Results

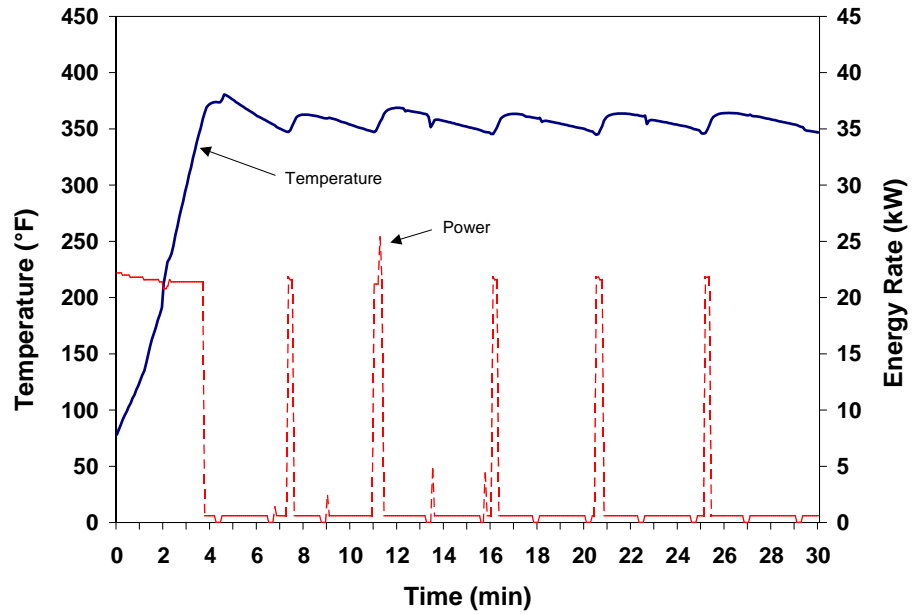

Figure 3-1.
Preheat characteristics.

Idle Energy Rate

The idle energy and water consumption rates in combination mode were 1.7 kW and 0.2 gal/h, respectively. Table 3-2 summarizes the results from the ASTM idle test, as well as the two additional tests that were run in dry heat and steam modes.

Table 3-2. Idle Test Results.

	Combination Mode	Dry Heat Mode	Steam Mode
Oven Setpoint (°F)	350	350	212
Idle Energy Rate (kW)	1.7	1.2	4.0
Idle Duty Cycle (%)	7.8	5.6	18.9
Water Consumption Rate (gal/h)	0.2	0.0	8.4

Results

Cooking Tests

For the heavy-load tests, the cook time was 34.3 minutes, with a cooking-energy efficiency of 80.2%. The cooking-energy rate during the tests was 13.4 kW. Production capacity was 114.4 lb/h, with a product shrinkage of 28.4%. Water consumption was 9.7 gallons, which equaled a rate of 17.0 gal/h. The maximum drain water temperature was 157°F, and the average drain water temperature was 102°F.

The light-load tests were completed in 33.0 minutes, with a cooking-energy efficiency of 65.5%. The cooking-energy rate during the light-load tests was 6.5 kW. The production rate was 41.0 lb/h, and the product shrinkage was 27.0%. Maximum drain water temperature was 138°F, with an average of 91°F.

Test Results

Cooking-energy efficiency is defined as the quantity of energy consumed by the food and pans (or chicken racks) expressed as a percentage of energy consumed by the oven during the cooking test:

$$\text{Cooking-Energy Efficiency \%} = \frac{E_{\text{chicken}} + E_{\text{pans}}}{E_{\text{oven}}} \times 100\%$$

Energy imparted into the chicken is calculated using the measured values of initial and final temperature, initial and final weight, the specific heat of the chicken, and the heat of vaporization of water at 212°F. Energy imparted into the chicken racks is calculated using the measured values of initial and final temperature of the racks, weight of the racks, and the specific heat of the metal. Energy consumed by the test oven is determined by measuring electric energy use during the test.

Table 3-2 summarizes the results of the ASTM cooking-energy efficiency and production capacity tests. Figure 3-3 illustrates the relationship between cooking-energy efficiency and production rate for the OES-10.10. Appendix

Results

D lists the physical properties and measured values of all the test variables for each test run.

Table 3-3. Whole Chicken Cooking Test Results.

	Heavy-Load	Light-Load
Number of Chickens	27	9
Cook Time (min)	34.3	33.0
Cooking Energy Rate (kW)	13.4	6.5
Cooking-Energy Efficiency (%)	80.2 ± 2.7	65.5 ± 4.2
Production Rate (lb/h)	114.4 ± 8.1	41.0 ± 3.7
Product Shrinkage (%)	28.4	27.0
Energy Consumed by Oven (Btu/lb)	399	544
Average Condensate Temperature (°F)	102	91
Water Consumption (gal/h)	17.0	5.1

Figure 3-2 illustrates the relationship between cooking-energy efficiency and production rate for the OES-10.10 combi oven. The oven's production rate is a function of the number of chickens cooked and the cook time. Heavy loads exhibit higher efficiencies due to better use of the available compartment space, as opposed to light-load single rack tests, where most of the space in the cooking compartment is empty.

Results

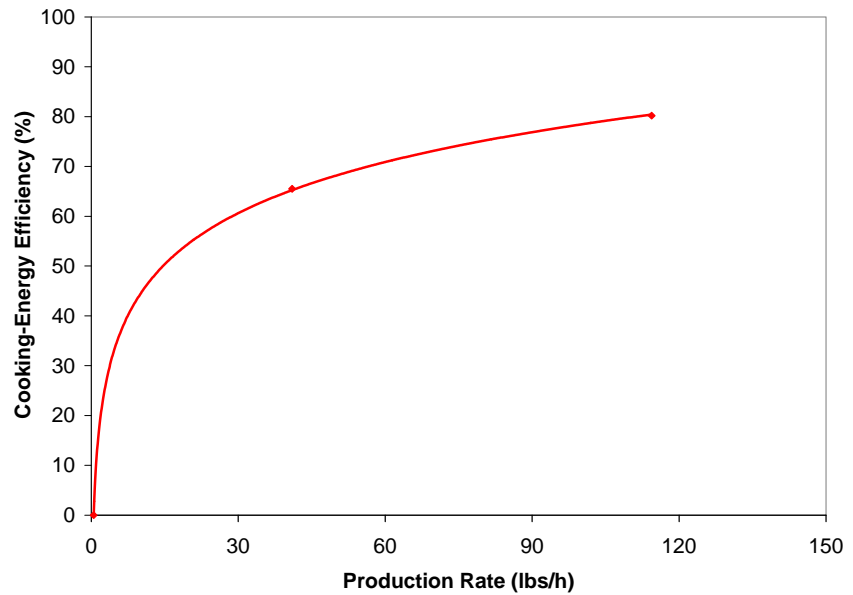

*Figure 3-2.
Combi part-load cooking-energy efficiency.*

Note: Light-load = single rack/load; Heavy-load = 4 racks/load.

Figure 3-3 represents the cooking energy rate for the two test load scenarios. This graph can be used as a tool to estimate the daily energy consumption and probable demand for the combi in a real-world operation, based on the type of usage. End-use monitoring studies have shown that an electric appliance's *probable* contribution to the building's peak demand is equal to the appliance's average energy consumption rate during a typical day.⁹ The average energy consumption rates for the OES-10.10 at 30 and 60 pounds per hour of whole chickens are 5.0 and 8.0 kW, respectively. For an operation cooking an average of 15 pounds of food per hour over the course of the day (e.g. 150 lb of food over a ten hour day), the probable demand contribution for the OES-10.10 combi oven would be 3.5 kW.

Results

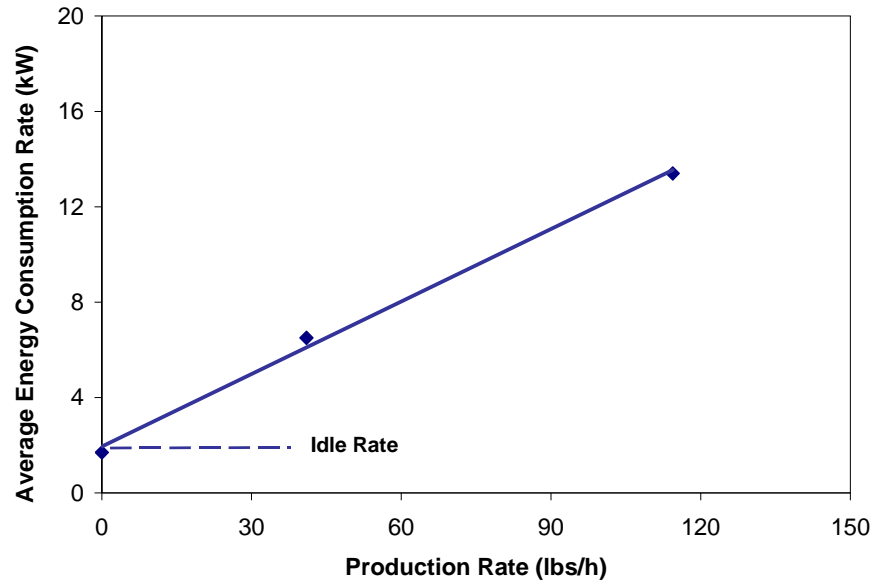

Figure 3-3.
Combi cooking energy
consumption profile.

Note: Light-load = single rack/load (9 whole chickens); Heavy-load = 2 racks/load (18 whole chickens).

Ice-Load Uniformity Test

To evaluate the cooking uniformity of the OES-10.10, researchers referred to the ice-load uniformity test contained in the *ASTM Standard Test Method for the Performance of Steam Cookers*.¹⁰

The ice-load uniformity test was designed to emulate frozen vegetables, while allowing researchers to accurately monitor simulated food temperature during the cooking event. For each test, 10 full-size hotel pans filled with ice were used to determine the steaming uniformity within the cooking cavity. During the test, the last pan reached a temperature of 170°F in 32.5 minutes. At this time, the maximum temperature difference between the hottest and coldest pan was 7.3°F. The last pan to reach the 170°F endpoint required an additional 1.9 minutes beyond the cook time of the fastest pan. Figure 3-4 shows the individual pan temperatures during a single ice-load test and Table 3-4 summarizes the results of the ice-load uniformity test.

Results

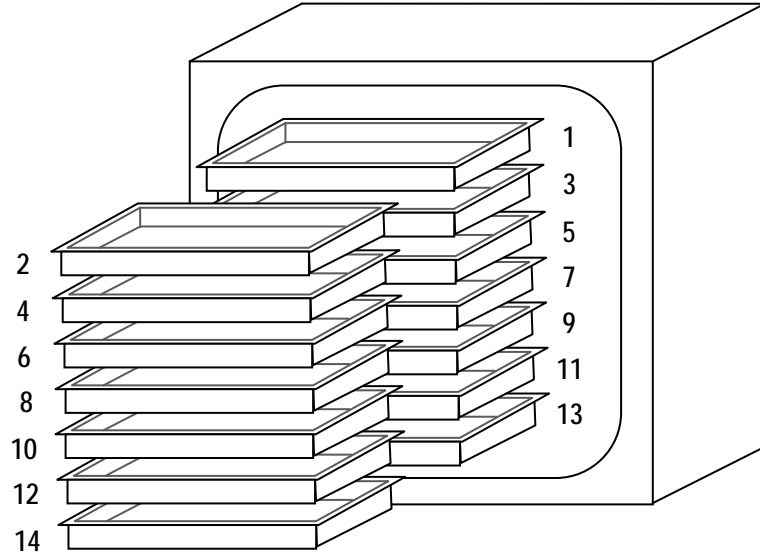

Figure 3-4.
Ice-load pan positions.

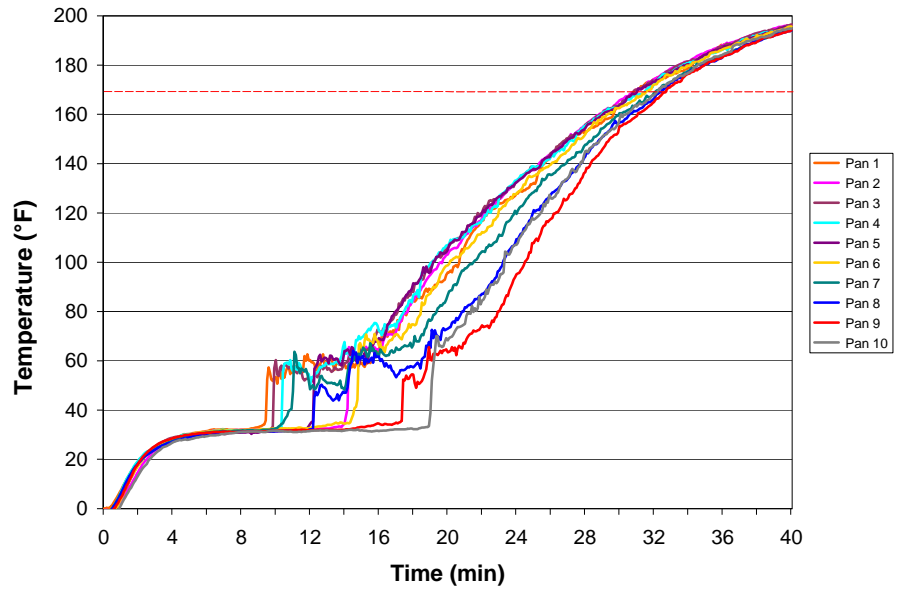

Figure 3-5.
Ice-load temperature
profile.

Results

Table 3-4. Ice-Load Uniformity Test Results.

Number of Pans	10
Cook Time (min)	32.5
Initial Ice-Load Temperature (°F):	- 0.2
Final Ice-Load Temperatures (°F):	174.0
Pan 1 (Top)	175.2
Pan 2	177.6
Pan 3	177.4
Pan 4	176.2
Pan 5	176.1
Pan 6	176.2
Pan 7	172.3
Pan 8	171.1
Pan 9	170.2
Pan 10 (Bottom)	172.5
Maximum Temperature Difference (°F)	7.3
Maximum Time Delay* (min)	1.9

* Time required for ice load in last pan to reach 170°F after first pan reaches the endpoint.

Energy Cost Model

Appliance test results are useful not only for benchmarking appliance performance, but also for estimating appliance energy consumption.

Assuming the OES-10.10 oven cooked 200 lbs of food a day (12 hours), 365 days a year, with two preheats per day, and assuming \$0.10/kWh, its estimated annual cost to operate would be \$1,602 per year.

4 Conclusions

The OES 10.10 demonstrated an impressive 80.2% cooking energy efficiency, while producing 114.4 lbs/h. When cooking the heavy-loads, water usage was 17.0 gallons per hour. During the idle test in combination mode, the consumption rate dropped to only 0.2 gal/h.

The combi's closed system design resulted in a low 1.7 kW idle energy rate. During the ice load tests, the OES-10.10 exhibited strong pan to pan uniformity, with a maximum delay of 1.9 minutes between the fastest and slowest pans.

With low energy and water consumption combined with high production rates, the Cleveland OES-10.10 combination oven is worthy of consideration by facilities looking to add versatility without adding significant operating costs.

5 References

1. American Society for Testing and Materials, 2005. *Standard Test Method for the Performance of Combination Ovens*. ASTM Designation F1639–05. In annual book of ASTM Standards, West Conshohocken, PA.
2. Zabrowski, D., Young, R., Ardley, S., Knapp, S., Selden, S., 1995. *Delicatessen Appliance Performance Testing*. Food Service Technology Center Report 5016.95.23. October.
3. Sorensen, G., 2003. *Rational ClimaPlus Combi® Model CPC 61 Combination Oven: Application of ASTM Standard Test Method F1639-95*. Food Service Technology Center Report 5011.03.10, January.
4. Zabrowski, D., Sorensen, G., Kong, V., 2005. *BKI 1.10 Electric Combination Oven Performance Testing: Application of ASTM Standard Test Method F1639-05*. Food Service Technology Center Report 5011.05.15, September.
5. Sorensen, G., Zabrowski, D., 2006. *Cleveland, Model OES-6.20 Electric Combination Oven Performance Test: Application of ASTM Standard Test Method F1639-05*. Food Service Technology Center Report 5011.06.01, April.
6. Sorensen, G., Zabrowski, D., 2006. *Cleveland, Model OGS-6.20 Gas Combination Oven Performance Test: Application of ASTM Standard Test Method F1639-05*. Food Service Technology Center Report 5011.06.02, April.
7. Sorensen, G., Zabrowski, D., 2006. *Rational, Model SCC 62G Gas Combination Oven Performance Test: Application of ASTM Standard Test Method F1639-05*. Food Service Technology Center Report 5011.06.10, June.
8. Sorensen, G., 2007. *Cleveland, Model OEB-6.20 Electric Combination Oven Performance Test: Application of ASTM Standard Test Method F1639-05*. Food Service Technology Center Report 5011.07.11, July.
9. Pieretti, G., Blessant, J., Kaufman, D., Nickel, J., Fisher, D., 1990. *Cooking Appliance Performance Report*. Food Service Technology Center Report 008.1-90.8, May.
10. American Society for Testing and Materials, 2005. *Standard Test Method for the Performance of Steam Cookers*. ASTM Designation F1484–05. In annual book of ASTM Standards, West Conshohocken, PA.

A Glossary

Boiler

Self-contained electric, gas, or steam coil powered vessel wherein water is boiled to produce steam for the steam cooker. Also called a steam generator.

Condensate

A mixture of condensed steam and cooling water, exiting the steam cooker and directed to the floor drain.

Condensate Temperature (°F)

The temperature at which the condensate enters the floor drain.

Cooking Energy (kWh or kBtu)

The total energy consumed by an appliance as it is used to cook a specified food product.

Cooking Energy Consumption Rate (kW or kBtu/h)

The average rate of energy consumption during the cooking period.

Cooking-Energy Efficiency (%)

The quantity of energy input to the food products; expressed as a percentage of the quantity of energy input to the appliance during the heavy- and light-load tests.

Duty Cycle (%)

Load Factor

The average energy consumption rate (based on a specified operating period for the appliance) expressed as a percentage of the measured energy input rate.

$$\text{Duty Cycle} = \frac{\text{Average Energy Consumption Rate}}{\text{Measured Energy Input Rate}} \times 100$$

Energy Input Rate (kW or kBtu/h)

Energy Consumption Rate

Energy Rate

The peak rate at which an appliance will consume energy, typically reflected during preheat.

Heating Value (Btu/ft³)

Heating Content

The quantity of heat (energy) generated by the combustion of fuel. For natural gas, this quantity varies depending on the constituents of the gas.

Ice Load

12 x 20 x 2½ in. hotel pan filled with 8.0 ± 0.2 lb of water and subsequently frozen to 0±5°F. This is used to simulate a food product load in the ice load cooking uniformity test.

Idle Energy Rate (kW or Btu/h)

Idle Energy Input Rate

Idle Rate

The rate of appliance energy consumption while it is “holding” or maintaining a stabilized operating condition or temperature.

Idle Temperature (°F, Setting)

The temperature of the cooking cavity/surface (selected by the appliance operator or specified for a controlled test) that is maintained by the appliance under an idle condition.

Idle Duty Cycle (%)

Idle Energy Factor

The idle energy consumption rate expressed as a percentage of the measured energy input rate.

$$\text{Idle Duty Cycle} = \frac{\text{Idle Energy Consumption Rate}}{\text{Measured Energy Input Rate}} \times 100$$

Glossary

Measured Input Rate (kW or Btu/h)

Measured Energy Input Rate
Measured Peak Energy Input Rate

The maximum or peak rate at which an appliance consumes energy, typically reflected during appliance preheat (i.e., the period of operation when all burners or elements are “on”).

Pilot Energy Rate (kBtu/h)

Pilot Energy Consumption Rate

The rate of energy consumption by the standing or constant pilot while the appliance is not being operated (i.e., when the thermostats or control knobs have been turned off by the food service operator).

Preheat Energy (kWh or Btu)

Preheat Energy Consumption

The total amount of energy consumed by an appliance during the preheat period.

Preheat Rate (°F/min)

The rate at which the cooking surface heats during a preheat.

Preheat Time (minute)

Preheat Period

The time required for an appliance to heat from the ambient room temperature ($75 \pm 5^\circ\text{F}$) to a specified (and calibrated) operating temperature or thermostat set point.

Production Capacity (lb/h)

The maximum production rate of an appliance while cooking a specified food product in accordance with the heavy-load cooking test.

Production Rate (lb/h)

Productivity

The average rate at which an appliance brings a specified food product to a specified “cooked” condition.

Rated Energy Input Rate

(kW, W or Btu/h, Btu/h)
Input Rating (ANSI definition)
Nameplate Energy Input Rate
Rated Input

The maximum or peak rate at which an appliance consumes energy as rated by the manufacturer and specified on the nameplate.

Steam Cooker

Cooking appliance wherein heat is imparted to food in a closed compartment by direct contact with steam. The compartment can be at or above atmospheric pressure. The steam can be static or circulated.

Test Method

A definitive procedure for the identification, measurement, and evaluation of one or more qualities, characteristics, or properties of a material, product, system, or service that produces a test result.

Typical Day

A sampled day of average appliance usage based on observations and/or operator interviews, used to develop an energy cost model for the appliance.

Water Consumption (gal/h)

Water consumed by the steam cooker. Includes both water used in the production of steam and cooling water (if applicable) for condensing/cooling unused steam.

B Appliance Specifications

Appendix B includes the product literature for the Cleveland, Model OES-10.10 electric combination oven.



COMBI OVEN-STEAMER



Featuring the
"Advanced Closed System +3"

ELECTRIC HEATED – Boilerless**Cooking Modes:**

- Hot Air
- Retherm
- "Delta T" slow cooking
- Steam
- "Cook & Hold"
- "Crisp & Tasty"
- Combi

Cleveland Standard Features:

- "Advanced closed system" with "Crisp & Tasty" de-moisturizing feature
- Efficient heating system saves energy and provides fast heat up times
- Fully insulated cooking compartment for maximum energy savings
- Polished cooking compartment with coved corners for easy cleaning
- Three (3) 12" x 20" wire shelves
- Hinged fan guard and hinged removable pan racks
- Two (2) speed auto reversing convection fan for even heat distribution
- Space saving, easy to close **"Disappearing Door"**
- Door latch with safety vent position and wear-free door switch
- Vented, double glass door with integrated door stop and self draining condensate drip pan
- Easy to change, press-fit door seal
- Oven light with shock resistant safety glass
- Multipoint core temperature probe
- Easy to use electronic controls for all operational functions
- Self diagnostic system with full text message display
- Easy to understand menu icons with bright graphics display
- User friendly selector dial
- Exclusive **"Smart Key"** for selecting option settings
- Digital controls for temperature, time and core probe settings
- Eight (8) **"Press & Go"** one step, recipe start buttons
- Cook book library for up to 250 stored recipe programs, each recipe capable of 20 steps
- RS 232 connection for controlling one unit with a PC (personal computer)
- Memory module automatically saves unit settings and recipes
- Manual program override feature for operational settings
- Smooth action hand shower for compartment cleaning
- Injection system for steam

Options and Accessories

- ConvoClean automatic compartment washing system
- PC-HACCP software for establishing "HACCP controls" and automatic documentation of the cooking process
- Equipment stand(s)
- Equipment stand(s) with Casters

MODEL: OES-10.10

CAPACITY: TEN (10) – 12" by 20" by 2 1/2" steam table pans

ITEM NUMBER _____

JOB NAME / NUMBER _____

**Short Form Specifications**

Shall be Cleveland Model: OES-10.10 Combination Convection Oven / Steamer with simple to operate electronic programmable controls for Hot Air, Convection Steam, and Combination cooking modes, **"Cook & Hold"** and **"Delta T"** slow-cooking capabilities, **"Advanced Closed System"** with **"Crisp & Tasty"** de-moisturizing feature. Multiple cooking stage programs, stored recipe library, multipoint core temperature probe, **"Press & Go"**, one-step recipe start buttons, **"Smart Key"** for selecting option settings, two (2) speed auto reversing convection fan, boilerless. **"Disappearing Door"**. Capacity for ten (10) 12" x 20" x 2 1/2" pans. pans.

- Stacking kit for mounting one (1) OES-6.10 model on top of one (1) OES-10.10
- Lockable cover over operating controls for prison installations
- USB or RS 485 connection for networking and controlling up to 32 units with a personal computer
- Plate rack for banquet operations
- Plate rack cart
- Thermal cover for plate or pan rack
- ConvoClean compartment cleaning solution
- ConvoCare concentrate for compartment rinse cycle
- "Dissolve" generator descaling solution
- Chicken Grill Rack
- 12" x 20" Wire Baskets for frying products
- Additional 12" x 20" Wire Shelves

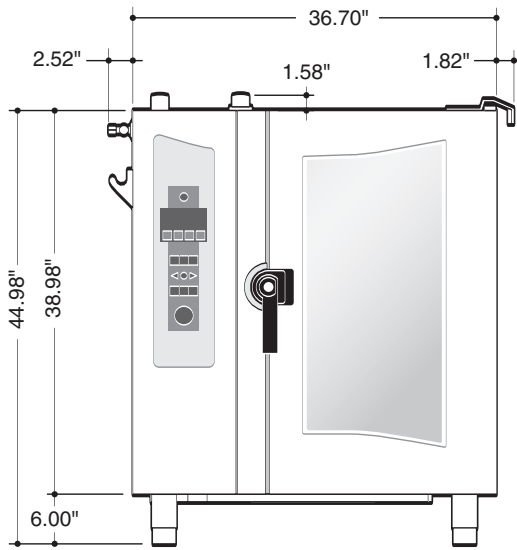

FRONT VIEW

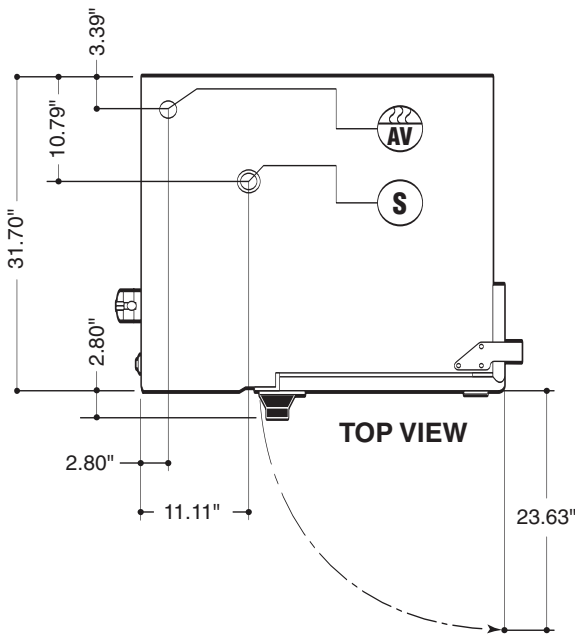

TOP VIEW

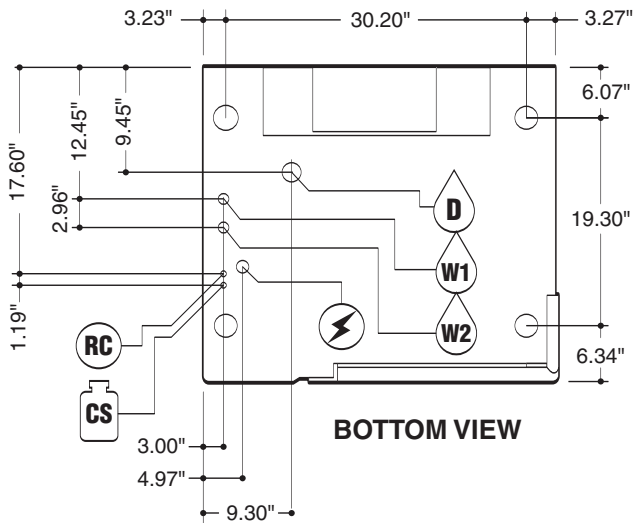

BOTTOM VIEW

The "Advanced Closed System" offers the following advantages:

- Saves energy
- Automatic moisture level adjustment
- Low heat and steam emission to the kitchen
- Automatically regulated steam injection
- Enables immediate change into the steam mode
- "Crisp & Tasty" demisterizing function

Model: OES-10.10

Pan Capacity [Unit has 11 slide rails at 2.64" (67mm) apart]:

- 10 (12" x 20" x 2 1/2") steam table pans
- 11 (12" x 20" x 1") steam table pans
- 11 (13" x 20") half size wire racks
- 11 (13" x 18") half size sheet pans
- 10 (12" x 20") frying baskets - (no wire racks needed)

For Banquet Operations: Optional Plate Rack holds 32 plates

Unit Dimensions: Width - 41.04", Depth - 34.50", Height - 45.68"

Shipping Dimensions: Width - 47", Depth - 41", Height - 54" (including packaging)

Shipping Weight: 475 Lbs

Required Clearances: Rear - 2", Left Side - 4", Right Side - 2 1/2"

- Allow for sufficient distance if a "high heat source" (i.e. Broiler) is located next to the unit.
- Allow for sufficient clearance on left side for service access (contact the factory service department for recommendations).
- Installation must comply with all local fire and health codes.

Agency Approvals: UL, UL - Sanitation (NSF Standards)



Electrical Requirements:	208/3/60	240/3/60	440/3/60	480/3/60
Total Connected Load:	16.4 KW	21.6 KW	18.5 KW	22 KW
Hot Air:	14.7 KW	19.6 KW	16.5 KW	19.6 KW
Amps per Phase:	45.5	51.8	24.2	26.4

Do not connect to a G.F.I. outlet

Water Connections: Cold Water (drinking water quality)
Flow Pressure: 30 - 60 PSI
Water Inlets: 3/4" GHT-F (Female Garden Hose Connection)



Treated Water for Steam Production



Untreated Water for Condenser and Hand Shower



Drain Connection: 2" Tube

Venting: Exhaust Hood required



Air Vent



*Connection for Cleaning Solution



*Connection for Rinse Cycle



Low Pressure Safety Valve

*Available as an option

NOTES:

Cleveland Range reserves right of design improvement or modification, as warranted. Many regional, state and local codes exist and it is the responsibility of the owner and installer to comply with the codes. Cleveland Range equipment is built to comply with applicable standards for manufacturers.

C Results Reporting Sheets

Manufacturer: Cleveland
Model: OES-10.10
Date: May 2007

Test Combination Oven

Description of operational characteristics: The Cleveland, Model OES-10.10 Combi Oven, is a 10-pan capacity, boilerless, half-size electric combination oven. It is powered by 21.6 kW elements located on the left-hand side of the cooking cavity. Steam is introduced into the cavity by spraying water onto the heating elements, and it is distributed throughout the cavity using an auto-reversing fan. The oven can operate in convection, steam or combination modes. The 10.10 oven features a programmable electronic control panel for all oven functions. This allows the oven to cook various foods in steps (up to 20) that can combine combi, convection, and steam all in one program. An internal probe allows monitoring of product temperature during cooking and recipes can be designed to cook to a set time or an internal product temperature. Up to 250 recipes can be stored for later use, with 8 one-press recipe start buttons.

Apparatus

The combination oven was installed in accordance with the manufacturer's instructions under a 4-foot-deep canopy hood, with the lower edge of the hood 6 feet, 6 inches above the floor and a minimum of 6 inches inside the vertical front edge of the hood. The exhaust ventilation operated at a nominal rate of 300 cfm per linear foot of hood with the ambient temperature maintained between $75 \pm 5^\circ\text{F}$. All test apparatus were installed in accordance with Section 9 of the ASTM test method.¹

The combination oven was instrumented using a watt/watt-hour transducer, with a resolution of 10Wh. A computerized data acquisition system recorded test information at 5-second intervals for the entire test method application. All test apparatus were installed in accordance with Section 9 of the ASTM test method.

Energy Input Rate

Test Voltage	240 V
Measured	21.4 kW
Rated	21.6 kW
Percent Difference between Measured and Rated	0.9 %

Appliance Preheat Energy Consumption and Duration

Oven Setting	Combination Mode, 350°F
Test Voltage	240 V
Energy Consumption	1.28 kWh
Duration	3.6 min

Results Reporting Sheets

Appliance Idle Energy Rate

Oven Setting	Combination Mode, 350°F
Test Voltage	240 V
Idle Energy Rate	1.7 kW
Idle Water Consumption	0.2 gal/h

Whole Chicken Cooking Tests:

Heavy-Load:

Oven Setting	Combination Mode, 350°F
Test Voltage	240 V
Number of Chickens	27
Cooking Time	34.3 min
Cooking-Energy Efficiency	80.2 ± 2.7%
Cooking Energy Rate	13.4 kW
Production Capacity	114.4 ± 8.1 lb/h
Shrinkage	28.4 %
Water Consumption Rate	17.0 gal/h
Condensate Temperature Maximum	157°F
Condensate Temperature Average	102°F

Light-Load:

Oven Setting	Combination Mode, 350°F
Test Voltage	240 V
Number of Chickens	9
Cooking Time	33.0 min
Cooking-Energy Efficiency	65.5 ± 4.2%
Cooking Energy Rate	6.5 kW
Production Rate	41.0 ± 3.7 lb/h
Shrinkage	27.0 %
Water Consumption Rate	5.1 gal/h
Condensate Temperature Maximum	139°F
Condensate Temperature Average	91°F

Results Reporting Sheets

Ice-Loads Cooking Time, Temperature Uniformity

Oven Setting		Steam Mode, 212°F
Test Voltage		240 V
Cooking Time		32.5 min
Initial Average Temperature		-0.2°F
Final Average Temperature		174.0°F
Average Final Ice Load Temperatures	Pan 1 (Top)	175.2°F
	Pan 2	177.6°F
	Pan 3	177.4°F
	Pan 4	176.2°F
	Pan 5	176.1°F
	Pan 6	176.2°F
	Pan 7	172.3°F
	Pan 8	171.1°F
	Pan 9	170.0°F
	Pan 10 (Bottom)	172.5°F
Maximum Temperature Difference		7.3°F
Maximum Time Delay		1.9 min

D Cooking-Energy Efficiency Data

Table D-1. Specific Heat and Latent Heat.

Specific Heat (Btu/lb, °F)		
Whole Chickens		0.80
Stainless Steel (Racks)		0.11
Latent Heat (Btu/lb)		
Vaporization, Water		970

Cooking-Energy Efficiency Data

Table D-2. Heavy-Load Whole Chicken Data

	Replication 1	Replication 2	Replication 3
Measured Values			
Number of Chickens	27	27	27
Cook Time (min)	34.1	33.6	35.2
Oven Energy Consumption (kWh)	7.56	7.60	7.76
Temperature of Raw Chickens (°F)	39.3	39.0	39.0
Temperature of Cooked Chickens (°F)	200.1	200.1	200.1
Weight of Pans (lb)	11.520	11.510	11.510
Initial Weight of Raw Chickens (lb)	66.410	64.795	64.935
Final Weight of Cooked Chickens, including liquid (lb)	53.845	52.080	52.200
Net Weight of Cooked Chickens (lb)	48.120	56.220	46.150
Maximum Condensate Temperature (°F)	157.0	147.0	137.0
Average Condensate Temperature (°F)	106.9	100.4	98.6
Water Consumption (gal)	10.8	9.8	8.5
Calculated Values			
Sensible Heat (Btu)	8,543	8,351	8,369
Latent – Heat of Vaporization (Btu)	12,188	12,334	12,353
Total Energy to Food (Btu)	20,731	20,684	20,722
Energy to Food (Btu/lb)	312	319	319
Energy to Pans (Btu)	204	204	204
Energy Consumed by the Combination Oven (Btu)	25,802	25,939	26,485
Energy to Oven (Btu/lb of food cooked)	389	400	400
Results			
Cooking Energy Rate (kW)	13.3	13.6	13.2
Cooking-Energy Efficiency (%)	81.1	80.5	79.0
Production Capacity (lb/h)	116.9	115.7	110.7
Product Shrinkage (%)	27.5	28.7	28.9
Water Consumption (gal/h)	19.0	17.5	14.5

Cooking-Energy Efficiency Data

Table D-3. Light-Load Whole Chicken Data

	Replication 1	Replication 2	Replication 3
Measured Values			
Number of Chickens	9	9	9
Cook Time (min)	34.0	31.7	33.3
Oven Energy Consumption (kWh)	3.68	3.52	3.56
Temperature of Raw Chickens (°F)	39.5	39.1	38.0
Temperature of Cooked Chickens (°F)	200.0	200.0	200.1
Weight of Pans (lb)	5.594	5.594	5.594
Initial Weight of Raw Chickens (lb)	22.421	22.461	22.654
Final Weight of Cooked Chickens, including liquid (lb)	16.762	17.603	17.636
Net Weight of Cooked Chickens (lb)	15.924	16.632	16.732
Maximum Condensate Temperature (°F)	139.1	136.8	137.3
Average Condensate Temperature (°F)	93.0	88.6	91.0
Water Consumption (gal)	4.0	2.3	2.2
Calculated Values			
Sensible Heat (Btu)	2,879	2,891	2,938
Latent – Heat of Vaporization (Btu)	5,489	4,712	4,867
Total Energy to Food (Btu)	8,368	7,603	7,805
Energy to Food (Btu/lb)	373	339	345
Energy to Pans (Btu)	99	99	100
Energy Consumed by the Combination Oven (Btu)	12,560	12,014	12,150
Energy to Oven (Btu/lb of food cooked)	560	535	536
Results			
Cooking Energy Rate (kW)	6.5	6.7	6.4
Cooking-Energy Efficiency (%)	67.4	64.1	65.1
Production Rate (lb/h)	39.6	42.5	40.8
Product Shrinkage (%)	29.0	26.0	26.1
Water Consumption (gal/h)	7.1	4.3	4.0

Cooking-Energy Efficiency Data

Table D-4. Whole Chickens Cooking-Energy Efficiency and Production Capacity Statistics.

	Cooking-Energy Efficiency		Production Capacity
	Heavy-Load	Light-Load	
Replicate #1	81.1	67.4	116.9
Replicate #2	80.5	64.1	115.7
Replicate #3	79.0	65.1	110.7
Average	80.2	65.5	114.4
Standard Deviation	1.09	1.70	3.28
Absolute Uncertainty	2.72	4.21	8.13
Percent Uncertainty	3.40	6.40	7.11

E Energy Cost Model

Procedure for Calculating the Energy Consumption of a Combination Oven Based on Reported Test Results.

Appliance test results are useful not only for benchmarking appliance performance, but also for estimating appliance energy consumption. The following procedure is a guideline for estimating combination oven energy consumption based on data obtained from applying the appropriate test method.

The intent of this Appendix is to present a standard method for estimating oven energy consumption based on ASTM performance test results. The examples contained herein are for informational purposes only, and should not be considered an absolute. To obtain an accurate estimate of energy consumption for a particular operation, parameters specific to that operation should be used (for example, operating time and amount of food cooked under heavy and light loads).

The calculation will proceed as follows: First, determine the appliance operating time and total number of preheats. Then estimate the quantity of food cooked and establish the breakdown among heavy (fully loaded oven), and light (single-rack) loads. For example, an oven operating for 12 h a day with two preheats cooked 200 lb of food: 80% of the food was cooked under heavy-load conditions and 20% was cooked under light-load conditions. Calculate the energy due to cooking heavy- and light-load cooking rates, and then calculate the idle energy consumption. The total daily energy is the sum of the components plus the preheat energy. For simplicity, assume that subsequent preheats require the same time and energy as the first preheat of the day.

The application of the test method to the OES-10.10 electric combination oven yielded the following results:

Energy Cost Model

Table E-1: Electric Oven Test Results.

Test	Result
Preheat Time	3.6 min
Preheat Energy	1.28 kWh
Idle Energy Rate	1.70 kW
Heavy-load cooking energy rate	13.4 kW
Light-load cooking energy rate	6.5 kW
Production Capacity	114.4 lb/h
Light-load production rate	41.0 lb/h

Step 1—The operation being modeled has the following parameters.

Table E-2: Oven Operation Assumptions.

Operating Time per Day	12 h
Operating Days per Year	365 d
Number of Preheats per Day	2
Total Amount of Food Cooked per Day	200 lb
Percentage of Food Cooked Under Heavy-load Conditions	80 %
Percentage of Food Cooked Under Light-load Conditions	20 %

Step 2—Calculate the total heavy-load energy.

The total time cooking heavy loads is as follows:

$$t_h = \frac{\%h \times W}{PC},$$

$$t_h = \frac{80\% \times 200 \text{ lb}}{114.4 \text{ lb/h}},$$

$$t_h = 1.40 \text{ h}$$

Energy Cost Model

The total heavy-load energy consumption is then calculated as follows:

$$E_{elec,h} = q_{elec,h} \times t_h,$$

$$E_{elec,h} = 13.4 \text{ kW} \times 1.40 \text{ h},$$

$$E_{elec,h} = 18.76 \text{ kWh}$$

Step 3—Calculate the total light-load energy.

The total time cooking light loads is as follows:

$$t_l = \frac{\%l \times W}{PR_l},$$

$$t_l = \frac{20\% \times 200 \text{ lb}}{41.0 \text{ lb/h}},$$

$$t_l = 0.98 \text{ h}$$

The total light-load energy consumption is then calculated as follows:

$$E_{elec,l} = q_{elec,l} \times t_l,$$

$$E_{elec,l} = 6.5 \text{ kW} \times 0.98 \text{ h},$$

$$E_{elec,l} = 6.37 \text{ kWh}$$

Step 4—Calculate the total idle time and energy consumption.

The total idle time is as follows:

$$t_i = t_{on} - t_h - t_l - \frac{n_p \times t_p}{60},$$

$$t_i = 12 \text{ h} - 1.40 \text{ h} - 0.98 \text{ h} - \frac{2 \text{ preheats} \times 3.6 \text{ min}}{60},$$

$$t_i = 9.5 \text{ h}$$

Energy Cost Model

The idle energy consumption is then calculated as follows:

$$E_{elec,i} = q_{elec,i} \times t_i,$$

$$E_{elec,i} = 1.7 \text{ kW} \times 9.5 \text{ h},$$

$$E_{elec,i} = 16.2 \text{ kWh}$$

Step 5—Calculate the total daily energy consumption as follows:

$$E_{elec,daily} = E_{elec,h} + E_{elec,l} + E_{elec,i} + (n_p \times E_{elec,p})$$

$$E_{elec,daily} = 18.76 \text{ kWh} + 6.37 \text{ kWh} + 16.2 \text{ kWh} + (2 \text{ preheats} \times 1.28 \text{ kWh})$$

$$E_{elec,daily} = 43.9 \text{ kWh/day}$$

Step 6—Calculate the average demand as follows:

$$q_{avg} = \frac{E_{elec,daily}}{t_{on}}$$

$$q_{avg} = \frac{43.9 \text{ kWh/day}}{12 \text{ h/day}}$$

$$q_{avg} = 3.7 \text{ kW}$$

Step 7—Determine the estimated annual appliance energy cost as follows:

$$C_{elec,annual} = r_{elec} \times E_{elec,daily} \times d_{op}$$

$$C_{elec,annual} = \$0.10/\text{kWh} \times 43.9 \text{ kWh/day} \times 365 \text{ days}$$

$$C_{elec,annual} = \$1,602/\text{year}$$